

TM 301 – TM 308

In-Line Torque Transducers

FEATURES

- Integrated Torque and Speed Conditioning
- Torque Range: 0.1 N·m to 20 N·m (0.07 lb-ft to 15 lb-ft)
- Accuracy: < 0.1%
(< 0.15% for TMB series and 0.2% for TM 301)
- Overload Capacity: 200%
- Overload Limit: 500%
- High Speed Applications: up to 50,000 rpm
- Non-Contact (no slippings)
- No Electronic Components in Rotation
- High Electrical Noise Immunity
- Single DC Power Supply: 20 VDC to 32 VDC
- Immediate Speed Detection
- Adjustable Torque Signal Frequency Limitation
- Built-in Test Function
- Stainless Steel Shaft
- EMC Susceptibility Conforms to European Standards

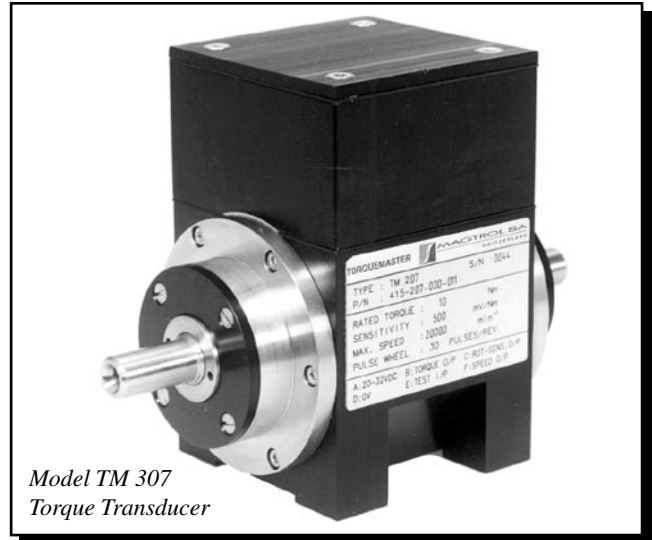

*Model TM 307
Torque Transducer*

DESCRIPTION

Magtrol's In-Line Torque Transducers provide extremely accurate torque and speed measurement over a very broad range. Each model has an integrated conditioning electronic module providing a 0 to ± 10 VDC torque output and an open collector speed output. Magtrol Torque Transducers are very reliable, providing high overload protection, excellent long term stability and high noise immunity.

All transducer models employ our unique non-contact differential transformer torque measuring technology. This measuring technology offers many benefits, most notably that no electronic components rotate during operation.

To provide customers with several price/performance options, Magtrol offers three torque transducer models: basic accuracy (TMB series), high accuracy (TM series) and high speed with high accuracy (TMHS).

Each transducer consists of a hardened stainless steel shaft with smooth shaft ends, an anodized aluminium housing containing the guide bearings and an electronic measurement conditioner.

The integrated electronic circuit, supplied by single DC voltage, provides torque and speed signals without any additional amplifier. Connections are made by means of a 6-pole male connector mounted on the housing, and fixed mounting is enabled by mounting holes located on the transducer.

APPLICATIONS

TM, TMB and TMHS Series Torque Transducers provide dynamic torque and speed measurement of:

- Propellers - aerospace, marine and helicopter
- Windshield wipers, electrical windows, starters, generators and brakes in automobile industry
- Pumps - water and oil
- Reduction gears and gearboxes
- Clutches
- Motorized valves
- Drills, pneumatic tools and other machine tools

BASIC SYSTEM CONFIGURATION

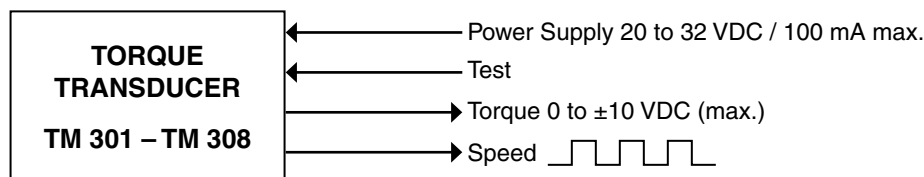

MODEL RATINGS

The ratings in the following table apply to all Torque Transducer series (TM, TMHS and TMB).

Model	Nominal Rated Torque		Torsional Stiffness		Moment of Inertia		Weight	
	<i>N·m</i>	<i>lb·ft</i>	<i>N·m/rad</i>	<i>lb·ft/rad</i>	<i>kg·m²</i>	<i>lb·ft·s²</i>	<i>kg</i>	<i>lb</i>
301 *	0.1	0.07	29	21	2.50×10^{-5}	1.84×10^{-5}	1.1	2.43
302 *	0.2	0.15	29	21	2.50×10^{-5}	1.84×10^{-5}	1.1	2.43
303	0.5	0.37	66	49	2.55×10^{-5}	1.89×10^{-5}	1.1	2.43
304	1	0.7	141	104	2.82×10^{-5}	2.08×10^{-5}	1.2	2.65
305	2	1.5	261	192	2.91×10^{-5}	2.15×10^{-5}	1.2	2.65
306	5	3.7	538	397	3.08×10^{-5}	2.27×10^{-5}	1.2	2.65
307	10	7.4	848	625	2.63×10^{-5}	1.94×10^{-5}	1.2	2.65
308	20	15	1176	867	2.66×10^{-5}	1.96×10^{-5}	1.2	2.65

* Models 301 and 302 available in TM Series only.

SERIES RATINGS

The ratings in the following table apply to all standard Torque Transducer models 301–308, unless otherwise noted.

Standard Version	TM Series	TMHS Series	TMB Series
TORQUE MEASUREMENT			
Rated Torque (RT)	0 to ±100% of RT		
Maximum Dynamic Torque Peak Value (Overload Capacity)	0 to ±200% of RT		
Maximum Dynamic Torque Without Damage (Overload Limit)	0 to ±500% of RT		
Combined Error of Linearity and Hysteresis to 100% of RT	< ±0.1% of RT (0.2% for TM 301)	< ±0.1% of RT	< ±0.15% of RT
Combined Error of Linearity and Hysteresis from 100% to 200% of RT	< ±0.1% of measured value (0.2% for TM 301)	< ±0.1% of measured value	< ±0.15% of measured value
Temperature Influence on the Zero/Sensitivity: • In the Compensated Range +10 °C to +60 °C • In the Compensated Range -25 °C to +80 °C	< ±0.1% of RT/10K < ±0.2% of RT/10K		< ±0.2% of RT/10K < ±0.4% of RT/10K
Influence of Speed on the Zero Torque Signal	< ±0.01% of RT/1000 rpm		< ±0.02% of RT/1000 rpm
Long-term Stability of Sensitivity	< ±0.05% of RT/year		< ±0.1% of RT/year
SPEED MEASUREMENT			
Rated Range of Use	1 to 20,000 rpm	TMHS 303: 1 to 40,000 rpm TMHS 304-308: 1 to 50,000 rpm	1 to 6,000 rpm
Number of Teeth	60 Z		
Minimum Speed Detection	1 rpm		
ENVIRONMENT			
Storage Temperature Range	-40 °C to +100 °C		
Operating Temperature Range	-40 °C to +85 °C		
Mechanical Shock	according to IEC 68.2.27 / Class D3		
Vibration	according to IEC 68.2.6 / Class D3		
Protection Class	IP 44		
MECHANICAL CHARACTERISTICS			
Shaft Ends	smooth		
Balancing Quality	G1 according to ISO 1940		G2.5 according to ISO 1940
INPUT AND OUTPUT SIGNALS			
Power Supply (max. voltage / current)	20 to 32 VDC / 100 mA		
Torque Output (rated / max.)	±5 / ±10 VDC		
Filter Cutoff (frequency)	5000, 2500, 1000, 500, 200, 100, 40, 20, 10, 5, 2, 1 Hz		
Speed Output (frequency)	open collector (15 Ω in series), max. 30 VDC, protected against short-circuits		
CONNECTORS			
Counter Connector (female)	optional (P/N 957.11.08.0081)		

OPERATING PRINCIPLES

The measuring system, based on the principle of a variable, torque-proportional transformer coupling, consists of two concentric cylinders shrunk on the shaft on each side of the shaft's deformation zone, and two concentric coils attached to the housing.

Both cylinders have a circularly disposed coinciding row of slots and rotate with the shaft inside the coils. An alternating current with the frequency of 20 kHz flows through the primary coil. When no torque is applied, the slots on the two cylinders fail to overlap. When torque is applied, the deformation zone undergoes an angular deformation and the slots begin to

overlap. Thus a torque-proportional voltage is on the secondary coil. The conditioning electronic circuit incorporated in the transducer converts the voltage to a nominal torque signal of 0 to ±5 VDC. A low-pass filter (Butterworth/2nd order), adjustable from 5 kHz to 1 Hz, allows tuning of the torque signal frequency limitation.

An optical sensor reads the speed on a toothed path machined directly on the measuring system. The electronic conditioner outputs a frequency signal proportional to the shaft rotational speed. An active circuit compensates the zero and sensitivity temperature drifts within a tolerance of 0.1% / 10 K.

DIMENSIONS

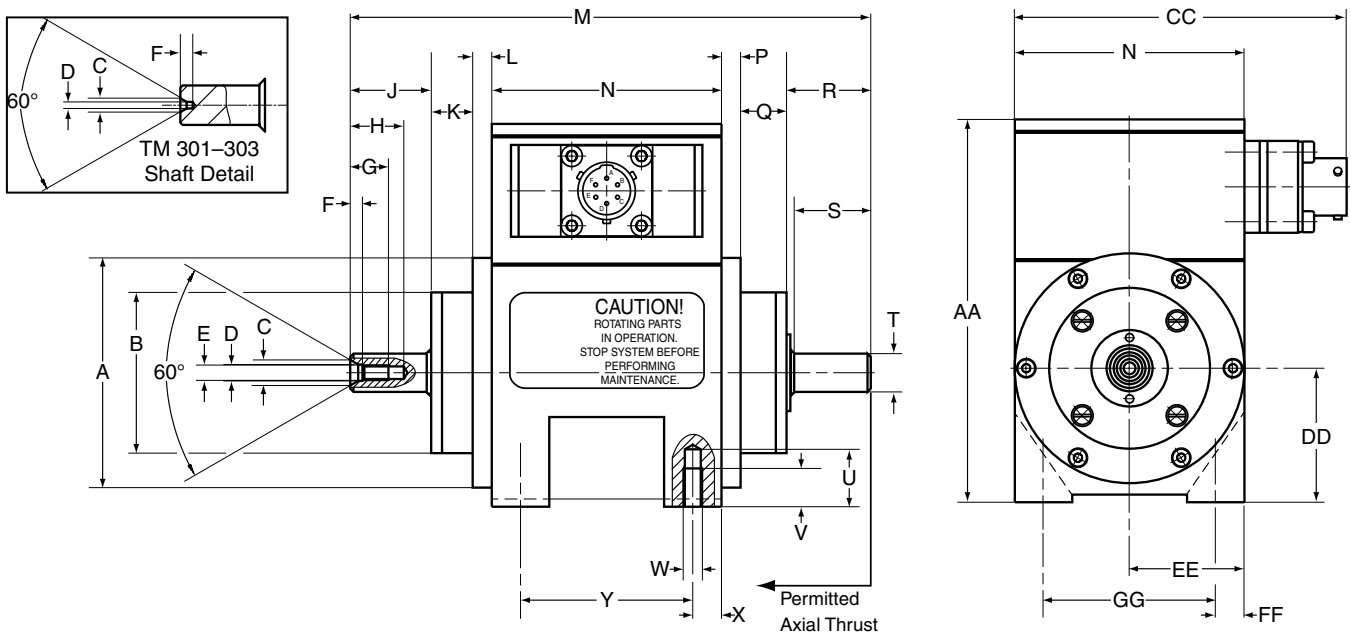

NOTE:

Dimensions are the same for every series (TM, TMHS, TMB).

Original dimensions are in Metric units. Dimensions converted to English have been rounded up to 3 or 4 decimal places.

Model	units	Ø A	Ø B	Ø C	Ø D	E	F	G	H	J	K	L	M	N	P	Q
301-303	mm	60	42g6	2.12	0.1	---	1.9	---	---	13.2	7.8	5	114	60	5	9
	in	2.362	1.6533 1.6526	0.083	0.004	---	0.075	---	---	0.520	0.307	0.197	4.488	2.362	0.197	0.354
304-308	mm	60	42g6	6.7	4.3	M4	3.2	10	14	21.2	10.8	5	136	60	5	12
	in	2.362	1.6533 1.6526	0.264	0.169	M4	0.126	0.394	0.551	0.835	0.425	0.197	5.354	2.362	0.197	0.472

Model	units	R	S	Ø T	U	V	W	X	Y	AA	CC	DD	EE	FF	GG
301-303	mm	14	12	6h6	15	10	M5	7.5	45	100	87	35 ±0.05	30	7.5	45
	in	0.551	0.472	0.2362 0.2359	0.591	0.394	M5	0.295	1.772	3.937	3.425	1.3799 1.3760	1.181	0.295	1.772
304-308	mm	22	20	10h6	15	10	M5	7.5	45	100	87	35 ±0.02	30 ±0.02	7.5	45
	in	0.866	0.787	0.3937 0.3933	0.591	0.394	M5	0.295	1.772	3.937	3.425	1.3787 1.3772	1.1819 1.1803	0.295	1.772

SYSTEM OPTIONS AND ACCESSORIES

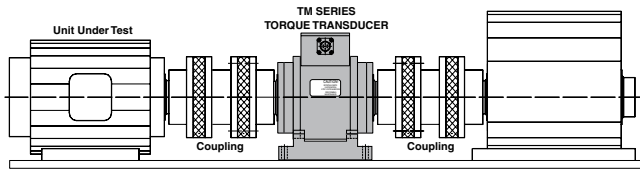

Supported Installation
Mandatory for high speed applications.

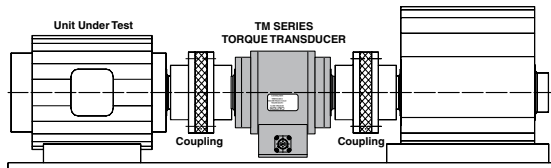

Suspended Installation
For low speed applications only, uses single-element couplings to create a shorter drive train.

Couplings

When Magtrol TMB, TM and TMHS Series Torque Transducers are to be mounted in a drive train, double-element miniature couplings are the ideal complement, although single-element couplings can be used for low speed applications. Several manufacturers provide adequate couplings for both supported and suspended drive train installations. The criteria for selecting appropriate couplings for torque measurement is as follows:

- High torsional spring rate: Ensures a high torsional stiffness and angular precision (should be greater than three times the torque transducer stiffness)
- Clamping quality (should be self-centering and of adequate strength)
- Speed range
- Balancing quality (according to speed range)
- Alignment capability

The higher the speed of the application, the more care is required in selecting the coupling and assembling (alignment and balancing) the drive train configuration. Your Magtrol sales representative can assist you in choosing the right coupling for your transducer.

ORDERING INFORMATION

Magtrol Torque Transducer model numbers must be preceded by the series type and followed by the appropriate suffix.

TORQUE TRANSDUCERS

- | | | |
|---------|--------------|--------------|
| • Model | TM 301-308 | TM 300/011 |
| • Model | TMHS 303-308 | TMHS 300/111 |
| • Model | TMB 303-308 | TMB 300/411 |

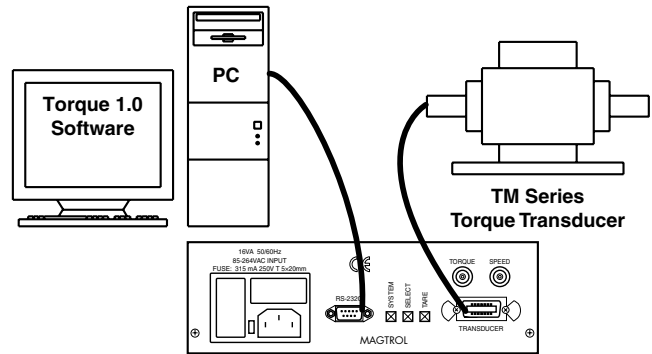

PC-Based System Configuration
Torque Transducer with Model 3410 Display and Torque 1.0 Software

Torque Transducer Displays

Magtrol offers two different Torque Displays (Models 3410 and 6400) which supply power to any TM/TMHS/TMB Transducer and display torque, speed and mechanical power. Features include:

- Adjustable English, metric and SI torque units
- Large, easy-to-read vacuum fluorescent display
- Built-in self-diagnostic tests
- Overload indication
- Tare function
- RS-232 interface
- Torque and speed outputs
- Closed-box calibration
- Includes Magtrol Torque 1.0 Software

The Model 6400 Display has the following additional features:

- Pass/fail torque-speed-power testing capabilities
- RS-232 and IEEE-488 interface
- Auxiliary analog input

Torque 1.0 Software

Magtrol's Torque 1.0 Software is an easy-to-use Windows® executable program, used to automatically collect torque, speed and mechanical power data. The data can be printed, displayed graphically or quickly saved as a Microsoft® Excel spreadsheet. Standard features of Torque 1.0 include: peak torque capture, multi-axes graphing, measured parameter vs. time, adjustable sampling rates and polynomial curve fitting.

Accessories	Model #
Torque Transducer Connector Cable (5/10/20 m)	ER 113

Due to the continual development of our products, we reserve the right to modify specifications without forewarning.



www.magtrol.com

MAGTROL INC

70 Gardenville Parkway
Buffalo, New York 14224 USA
Phone: +1 716 668 5555
Fax: +1 716 668 8705
E-mail: magtrol@magtrol.com

MAGTROL SA

Centre technologique Montena
1728 Rossens/Fribourg, Switzerland
Phone: +41 (0)26 407 3000
Fax: +41 (0)26 407 3001
E-mail: magtrol.ch

Subsidiaries in:

- Germany
 - France
 - Great Britain
 - China
- Worldwide Network
of Sales Agents

